

RECOMMENDED LAYOUT FOR -DV SCREW DOWN OPTIONS

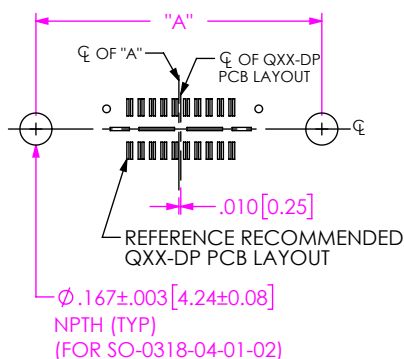
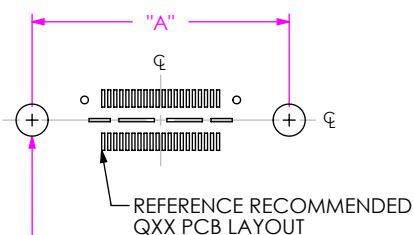
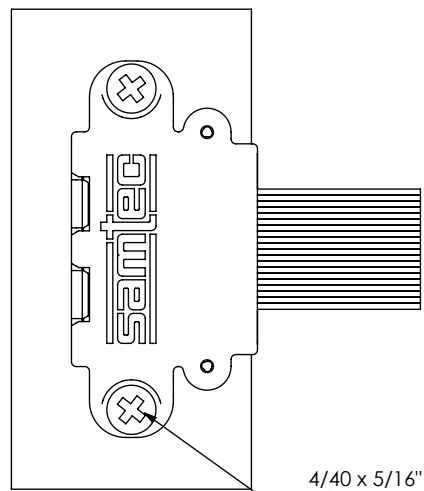
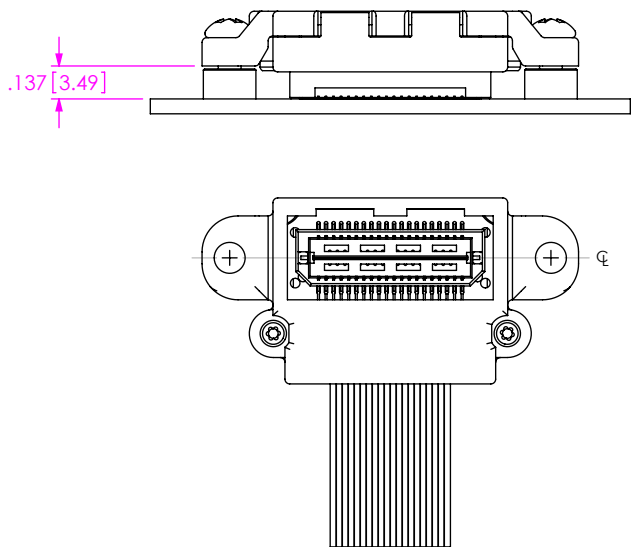

**TABLE 1**

EQCD No. OF POSITIONS	SQCD No. OF POSITIONS	HQCD No. OF POSITIONS	EQDP No. OF POSITIONS	EQSD No. OF POSITIONS	"A"
N/A	N/A	N/A	N/A	-020	1.439 [36.55]
N/A	N/A	N/A	N/A	-040	2.227 [56.57]
-020	-025	-030	-014	N/A	1.339 [34.00]
-040	-050	-060	-028	N/A	2.126 [54.00]
-060	-075	-090	-042	N/A	2.913 [74.00]
-080	-100	-120	-056	N/A	3.701 [94.00]

**TABLE 5**

HQDP No. OF POSITIONS	"A"
-020	1.489 [37.82]
-040	2.414 [61.32]
-060	3.339 [84.81]
-080	4.264 [108.31]



QXXX-DV WITH ANY SCREW-DOWN OPTION

NOTE: ALL DIMENSIONS ARE FOR REFERENCE ONLY

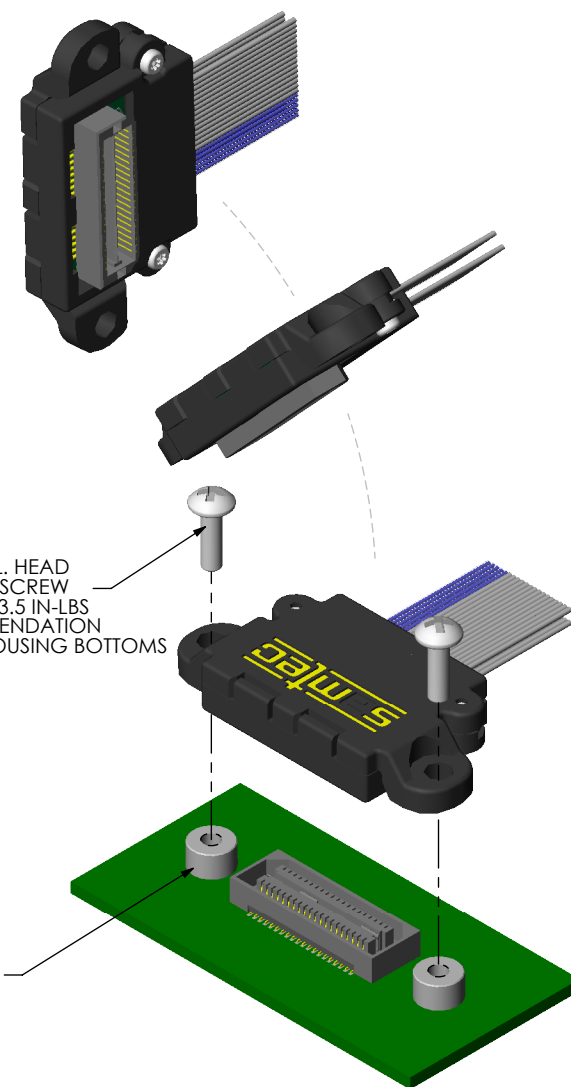

NOTE:  
THE NUT SHOWN CAN BE PURCHASED FROM SAMTEC (P/N SO-0318-04-01-02)  
OR PENN ENGINEERING (P/N KFE-440-12ET). HOWEVER, THE CUSTOMER IS  
FREE TO USE OTHER HARDWARE ACCEPTABLE TO THEM AS MOST OF THIS IS COMMODITY.  
(www.pemnet.com)

**PROPRIETARY NOTE**  
THIS DOCUMENT CONTAINS CONFIDENTIAL AND PROPRIETARY INFORMATION AND ALL DESIGN, MANUFACTURING, REPRODUCTION, USE, PATENT RIGHTS AND SALES RIGHTS ARE EXPRESSLY RESERVED BY SAMTEC, INC. THIS DOCUMENT SHALL NOT BE DISCLOSED, IN WHOLE OR PART, TO ANY UNAUTHORIZED PERSON OR ENTITY NOR REPRODUCED, TRANSFERRED OR INCORPORATED IN ANY OTHER PROJECT IN ANY MANNER WITHOUT THE EXPRESS WRITTEN CONSENT OF SAMTEC, INC.

DO NOT SCALE DRAWING  
SHEET SCALE: 1.25:1

**samtec**  
520 PARK EAST BLVD, NEW ALBANY, IN 47150  
PHONE: 812-944-6733 FAX: 812-948-5047  
e-Mail: info@SAMTEC.com code: 55322

DESCRIPTION: QXXX APPLICATIONS  
DWG. NO. QXXX WITH SCREW-DOWN OPTIONS  
BY: BRATCHER 11/17/2004 SHEET 1 OF 4

RECOMMENDED LAYOUT FOR -EM SCREW DOWN OPTIONS

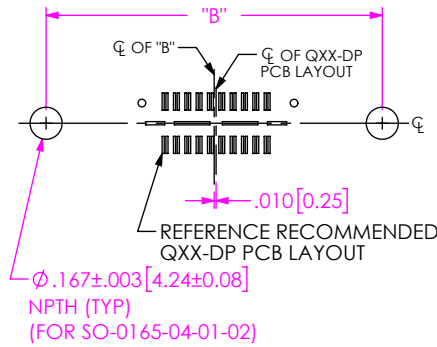
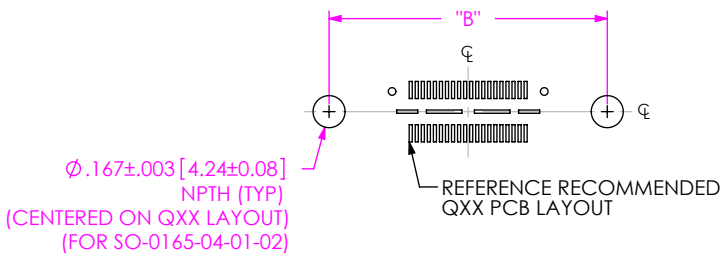

**TABLE 2**

EQCD No. OF POSITIONS	SQCD No. OF POSITIONS	HQCD No. OF POSITIONS	EQDP No. OF POSITIONS	EQSD No. OF POSITIONS	"B"
-020	-025	-030	-014	-020	1.449 [36.80]
-040	-050	-060	-028	-040	2.236 [56.80]
-060	-075	-090	-042	N/A	3.024 [76.80]
-080	-100	-120	-056	N/A	3.811 [96.80]

**TABLE 6**

HQDP No. OF POSITIONS	"B"
-020	1.751 [44.48]
-040	2.539 [64.49]
-060	3.326 [84.48]
-080	4.114 [104.50]

**XQXX-EM WITH ANY SCREW-DOWN OPTION**

NOTE: ALL DIMENSIONS ARE FOR REFERENCE ONLY

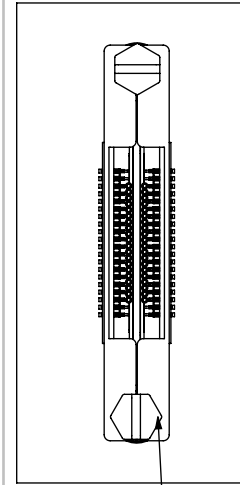

**S**  
CAPTIVE PANEL SCREWS  
TORQUE RANGE 0.5-1.0 IN-LBS  
(MAX TORQUE RECOMMENDATION  
CAN BE INCREASED IF HOUSING  
BOTTOMS OUT ON STANDOFF)

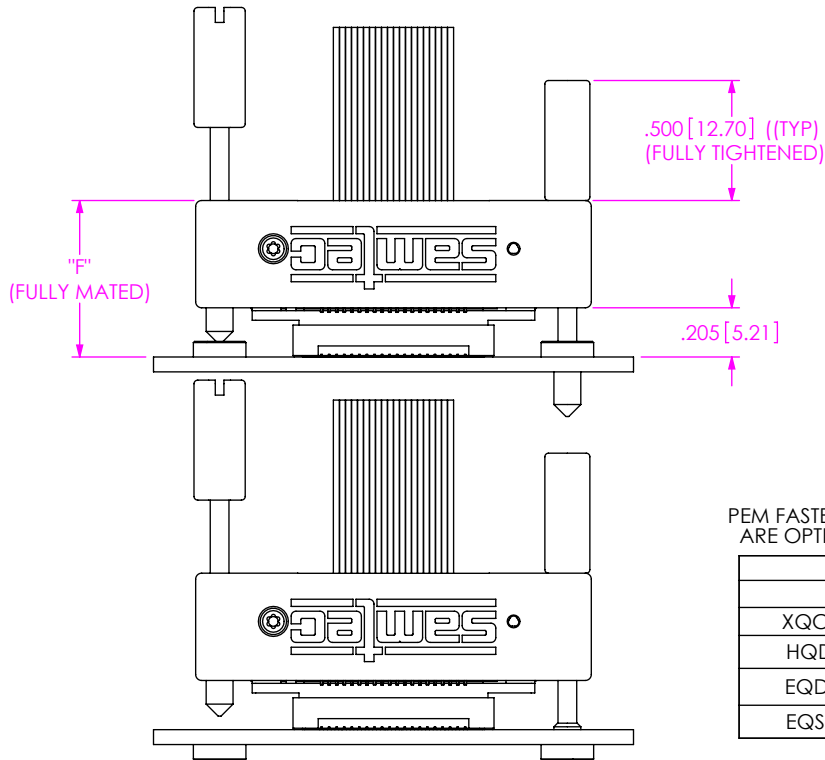
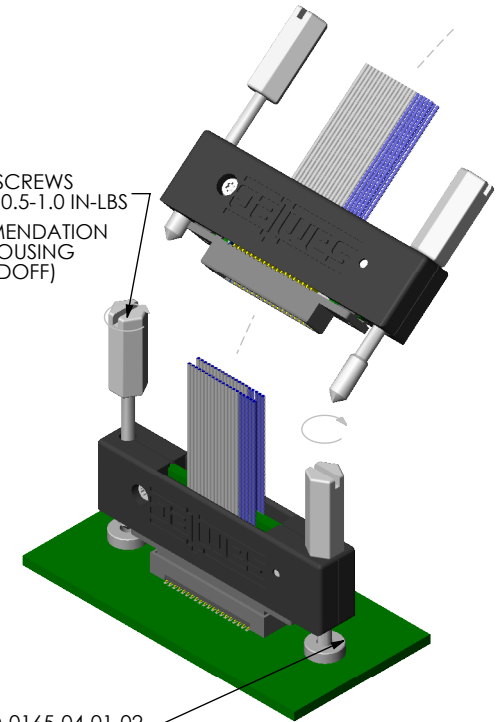

.285 [7.24]

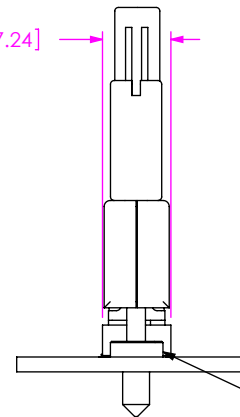

SO-0165-04-01-02

PEM FASTENERS ON TOP OR BOTTOM  
ARE OPTIONAL ASSEMBLY LAYOUTS

**TABLE 4**

	F
XQCD MATED	.652 [16.56]
HQDP MATED	.789 [20.04]
EQDP MATED	.652 [16.56]
EQSD MATED	.652 [16.56]

ALL DIMENSIONS THE SAME AS ABOVE  
UNLESS OTHERWISE STATED

**PROPRIETARY NOTE**  
THIS DOCUMENT CONTAINS CONFIDENTIAL AND PROPRIETARY INFORMATION AND ALL DESIGN, MANUFACTURING, REPRODUCTION, USE, PATENT RIGHTS AND SALES RIGHTS ARE EXPRESSLY RESERVED BY SAMTEC, INC. THIS DOCUMENT SHALL NOT BE DISCLOSED, IN WHOLE OR PART, TO ANY UNAUTHORIZED PERSON OR ENTITY NOR REPRODUCED, TRANSFERRED OR INCORPORATED IN ANY OTHER PROJECT IN ANY MANNER WITHOUT THE EXPRESS WRITTEN CONSENT OF SAMTEC, INC.

DO NOT SCALE DRAWING

SHEET SCALE: 1:25:1



520 PARK EAST BLVD, NEW ALBANY, IN 47150  
PHONE: 812-944-6733 FAX: 812-948-5047  
e-Mail: info@SAMTEC.com code: 55322

DESCRIPTION:  
XQXX APPLICATIONS

DWG. NO.  
XQXX WITH SCREW-DOWN OPTIONS

BY: BRATCHER 11/17/2004 SHEET 2 OF 4

**QQXX-BULK SCREW-DOWN OPTION**

NOTE: ALL DIMENSIONS ARE FOR REFERENCE ONLY

**RECOMMENDED PANEL OPENING FOR -BULK SCREW DOWN OPTIONS**  
(Ø .129 HOLES CENTERED ON PANEL OPENING)

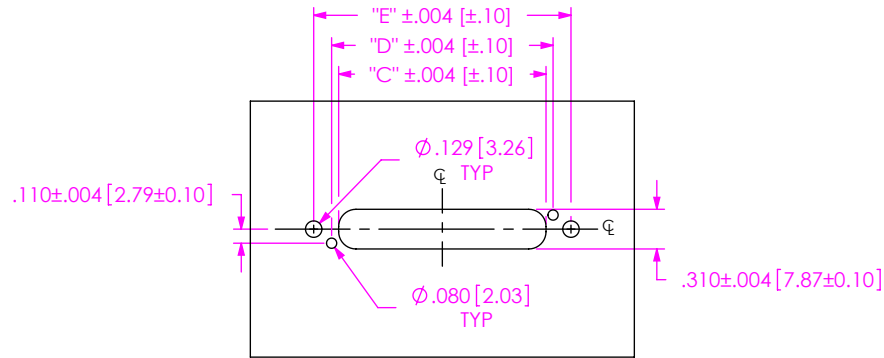

**TABLE 3**

EQCD	SQCD	HQCD	EQDP	HQDP	EQSD	"C"	"D"	"E"
No. OF POSITIONS	No. OF POSITIONS	No. OF POSITIONS	No. OF POSITIONS	No. OF POSITIONS	No. OF POSITIONS			
-020	-025	-030	-014	N/A	N/A	1.620 [41.15]	1.730 [43.94]	2.010 [51.05]
-040	-050	-060	-028	N/A	N/A	2.407 [61.14]	2.517 [63.94]	2.797 [71.05]
-060	-075	-090	-042	N/A	N/A	3.194 [81.14]	3.304 [83.93]	3.584 [91.04]
-080	-100	-120	-056	N/A	N/A	3.982 [101.13]	4.092 [103.93]	4.372 [111.04]

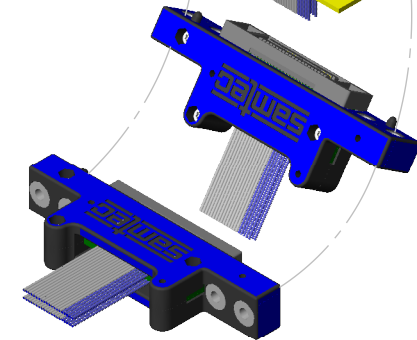
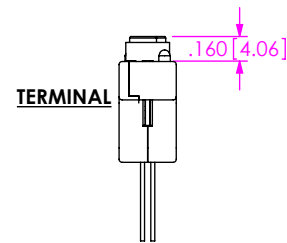
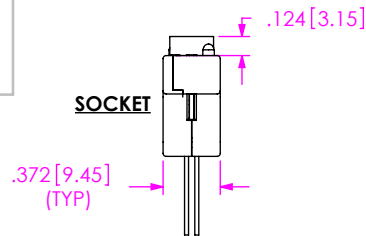
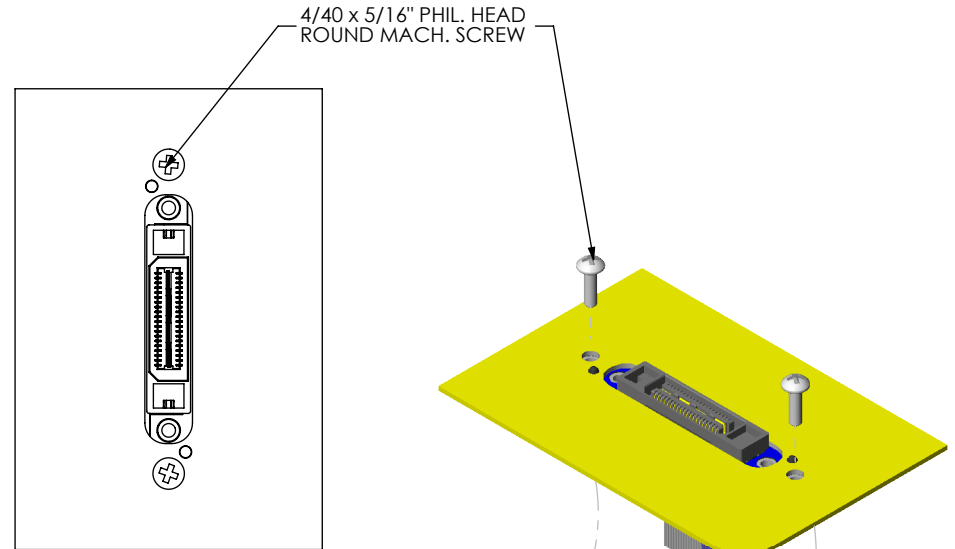
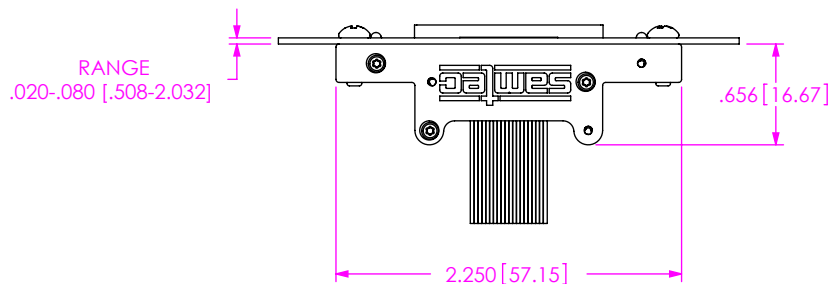
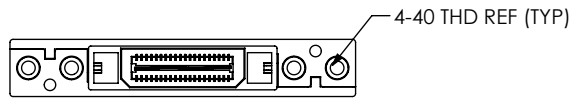

**PROPRIETARY NOTE**  
THIS DOCUMENT CONTAINS CONFIDENTIAL AND PROPRIETARY INFORMATION AND ALL DESIGN, MANUFACTURING, REPRODUCTION, USE, PATENT RIGHTS AND SALES RIGHTS ARE EXPRESSLY RESERVED BY SAMTEC, INC. THIS DOCUMENT SHALL NOT BE DISCLOSED, IN WHOLE OR PART, TO ANY UNAUTHORIZED PERSON OR ENTITY NOR REPRODUCED, TRANSFERRED OR INCORPORATED IN ANY OTHER PROJECT IN ANY MANNER WITHOUT THE EXPRESS WRITTEN CONSENT OF SAMTEC, INC.

DO NOT SCALE DRAWING

SHEET SCALE: 1:2



520 PARK EAST BLVD, NEW ALBANY, IN 47150  
PHONE: 812-944-6733 FAX: 812-948-5047  
e-Mail: info@SAMTEC.com code: 55322

DESCRIPTION:  
QQXX APPLICATIONS

DWG. NO.  
QQXX WITH SCREW-DOWN OPTIONS

BY: BRATCHER 11/17/2004 SHEET 3 OF 4

# SQCD TERMINAL-QSS RIGHT ANGLE SCREW-DOWN OPTION

NOTE: ALL DIMENSIONS ARE FOR REFERENCE ONLY

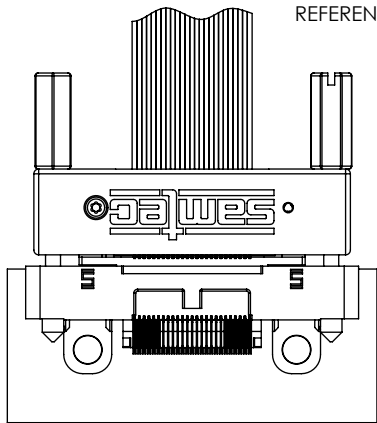

REFERENCE RECOMMENDED  
QSS PCB LAYOUT

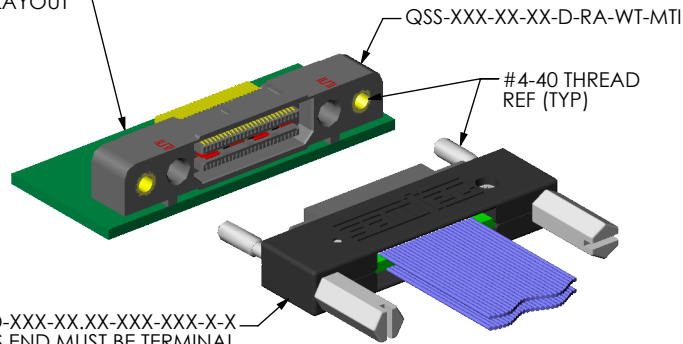

SQCD-XXX-XX.XX-XXX-XXX-X-X  
(THIS END MUST BE TERMINAL  
EDGEMOUNT WITH SCREW  
DOWN OPTION)

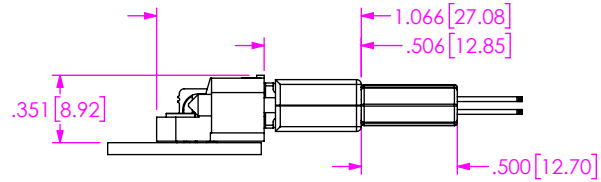
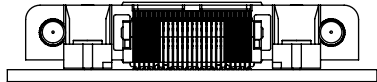

**PROPRIETARY NOTE**  
THIS DOCUMENT CONTAINS CONFIDENTIAL AND PROPRIETARY INFORMATION AND ALL DESIGN, MANUFACTURING, REPRODUCTION, USE, PATENT RIGHTS AND SALES RIGHTS ARE EXPRESSLY RESERVED BY SAMTEC, INC. THIS DOCUMENT SHALL NOT BE DISCLOSED, IN WHOLE OR PART, TO ANY UNAUTHORIZED PERSON OR ENTITY NOR REPRODUCED, TRANSFERRED OR INCORPORATED IN ANY OTHER PROJECT IN ANY MANNER WITHOUT THE EXPRESS WRITTEN CONSENT OF SAMTEC, INC.

DO NOT SCALE DRAWING  
SHEET SCALE: 1:1

**samtec**  
520 PARK EAST BLVD, NEW ALBANY, IN 47150  
PHONE: 812-944-6733 FAX: 812-948-5047  
e-Mail: info@SAMTEC.com code: 55322

DESCRIPTION:	XQXX APPLICATIONS
DWG. NO.	XQXX WITH SCREW-DOWN OPTIONS
BY:	BRATCHER 11/17/2004 SHEET 4 OF 4